

# Thread Whirling Tools



## For Perfect Long Threads on Swiss Type Machines

Thread Whirling is a fast and accurate way to thread long, small diameter parts in exotic materials such as titanium, stainless steel and Inconel.

Whirling inserts and holders can produce a wide range of medical parts such as dental implants and bone screws, automotive parts and semiconductor small parts.

Cutting is the result of the whirling ring rotating eccentrically at high speed about the slowly rotating workpiece. The advancement of the workpiece rotationally and the advancement of the tool head longitudinally correspond to the thread pitch required.

Turning direction of the whirling unit

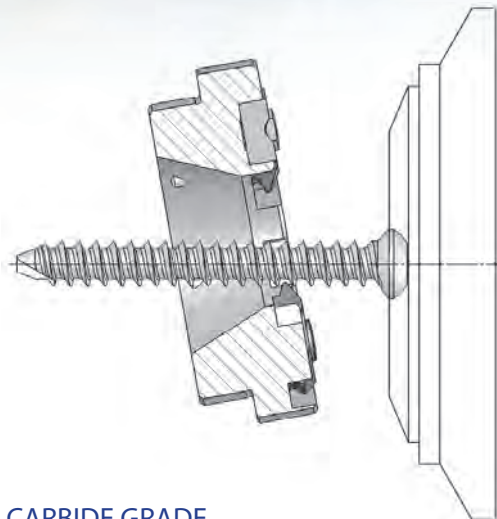

Turning direction of the bar



### CARBIDE GRADE

*BMA - PVD TiAlN coated submicrograin for stainless steel, exotic materials.*

#### Contents:

Thread Whirling Advantages	134
Product Identification	134
Ordering according to Machine Type or Model	135

#### Page: Contents:

Case study	136
Specials	136

#### Page:

## Thread Whirling Advantages

### Thread Whirling offers several advantages over single point threading:

Enabling production of small diameter long threads when used on Swiss type machines, the thread whirling spindle works close to the guide bushing for increased support and rigidity.

#### Increased Productivity:

Thread Whirling is performed in a single pass, resulting in a shorter machining time. This eliminates multiple passes required for a single point threading. Thread whirling allows working at high feed rates and consequently short cycle times.

#### Very high surface quality and accurate geometry:

The use of up to 8 cutting edges, higher concentricity, special cutting edge geometry and ideal chip removal, enable top quality surfaces to be produced without burr.

#### Long tool life:

Whirling inserts have a stronger cutting edge than single point tools, because cutter side clearance is achieved by rotating the whirling spindle, not by relieving material under the cutting edge.

#### Faster Setup:

Thread whirling eliminates special support devices and expensive startup development costs.

#### Compensation of large helix angles:

Large helix angles can be compensated by adjusting the whirling unit.

- One toolholder can be used for various applications.
- All toolholders are standard stock items.
- Inserts are made for each application as a special item.
- The toolholders are designed according to different machine types and manufacturers.
- Special adaptors for machine heads are available as stock items.

## Product Identification

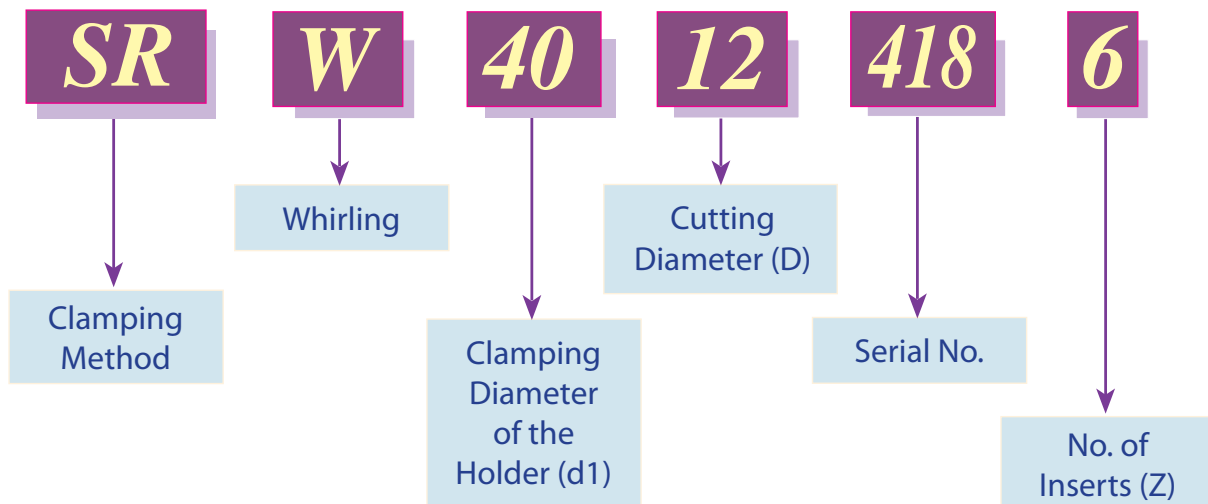

## Toolholders

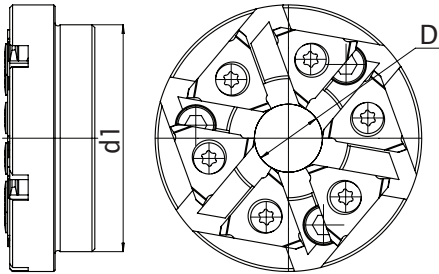

Machine		Drive Unit	Whirling Head Ordering Code	Z	D	d1	Insert Size	Insert Screw	Torx Key
Type	Model								
Star	SV12 / SV20	Star	SRW4012 418 - 6	6	12	40	16	SW16	KW16
			SRW4012 424 - 8	8			11	SW11	KW11
	SR20 / ECAS20		SRW4012 419 - 6	6	12	40	16	SW16	KW16
			SRW4012 425 - 8	8			11	SW11	KW11
Citizen	M12 / M16	PCM	SRW4512 422 - 6	6	12	45	16	SW16	KW16
			SRW4512 426 - 8	8			11	SW11	KW11
	M20 / M32		SRW4512 423 - 6	6	12	45	16	SW16	KW16
			SRW4512 427 - 8	8			11	SW11	KW11
Tornos	Deco 13 / 20	Tornos	SRW4012 420 - 6	6	12	40	16	SW16	KW16
	Evo Deco 16 / Deco 13	W & F	SRW4012 419 - 6						
Traub	TNL26 / TNK36	Traub	SRW4116 421 - 6	6	16	41	16	SW16	KW16
Hanwha	XD20	Maduala	SRW4012 604 - 6	6	12	40	16	SW16	KW16
Maier	ML20D	PCM	SRW4012 417 - 5	5	12	40	16	SW16	KW16
Nexturn	SA20	PCM	SRW4512 642 - 6	6	12	45	16	SW16	KW16
	SA20	WTO	SRW4212 557 - 6	6	12	45	16	SW16	KW16



## Case Study

Machine:	Nexturn SA-20
Drive unit:	WTO
Application:	Bone screw
Material:	Ti-6Al-4V ELI
Carmex holder:	SRW4212 557-6
Vc [m/min]:	38
Tooth load [mm/tooth]:	0.04
No. of parts:	806



**SPECIALS**  
ARE OUR SPECIALTY

